

PART NO.	DESCRIPTION	MATERIAL
SD548B	BRACKET ARM GUIDE 14 1/4" & 18 7/8" W/ DETENT BLANK STEEL	12 GA. COLD ROLLED STEEL
SD548B/S	BRACKET ARM GUIDE 14 1/4" & 18 7/8" W/ DETENT BLANK 316SS	12 GA. 316 STAINLESS STEEL

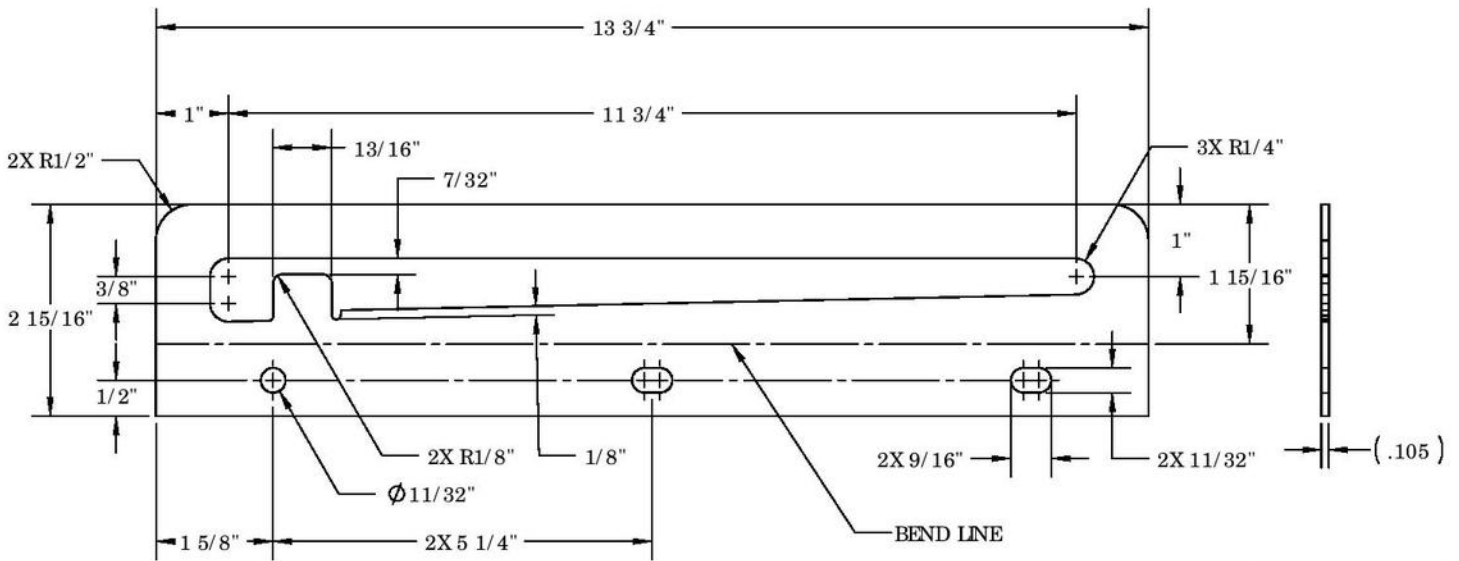

RELEASED TO
MANUFACTURING
DATE: 12/21/2010
APPROVED BY: D.J.C.

NOTES:

1. MATERIAL SEE TABLE

UNLESS OTHERWISE SPECIFIED:	NAME #	DATE
DRAWN	PRC	06/10/05
ORG. AUDITOR	TJ	
ORG. ECR	6874	05/02/00
Q.A.		

Wilco THE WILCO COMPANY
New Haven, Connecticut 06505

TITLE:
BRACKET ARM GUIDE 14 1/4"
& 18 7/8" W/ DETENT

REV.	DESCRIPTION	ECR	BY	DATE
F	ADDED MISSING DIMENSIONS	28854	ATR	12/20/10
E	RECREATED IN SOLIDWORKS	19610	PRC	05/10/05
D	NARROWED SLOT BY 1/8"	12210	DJC	04/26/02
C	ADDED MATERIAL CHART	7057	TJ	07/13/00
B	ADDED SLOTS	6978	MA	07/07/00

THIS DRAWING IS THE PROPERTY
OF THE WILCO COMPANY AND
IS NOT TO BE REPRODUCED
OR COPIED IN ANY MANNER
WITHOUT THE WRITTEN
CONSENT OF THE WILCO
COMPANY. THE INFORMATION
HEREIN REMAINS THE PROPERTY
OF THE WILCO COMPANY.
ALL RIGHTS RESERVED.

3RD-ANGLE PROJECTION
SEE NOTES
FIRST ANGLE
DO NOT SCALE DRAWING

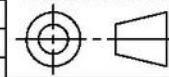

SIZE	DWG. NO.	REV
A	SD548	F

SCALE: 1:2 WEIGHT: SHEET 1 OF 3

PARTNO.	DESCRIPTION	MATERIAL	FINISH
SD548R	BRACKET ARM GUIDE 14 1/4" & 18 7/8" W/DETENT RH STEEL	MADE FROM SD548B	ZINC PLATED YELLOW CHROME
SD548R/S	BRACKET ARM GUIDE 14 1/4" & 18 7/8" W/DETENT RH 316SS	MADE FROM SD548B/S	----

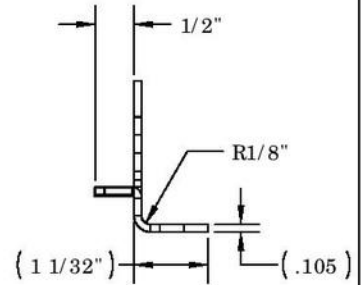
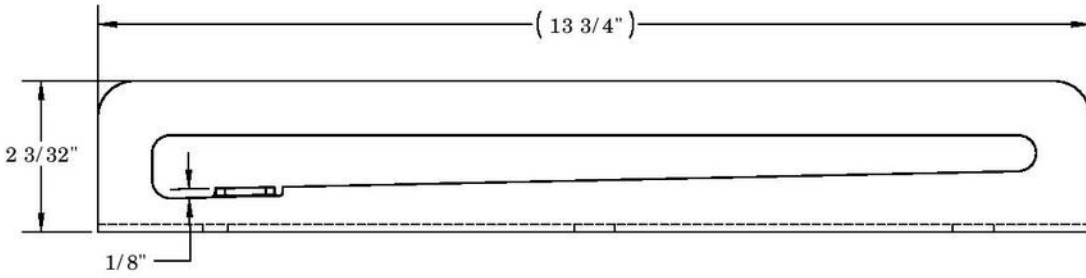
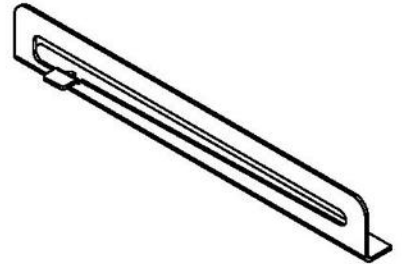

**RELEASED TO
MANUFACTURING**
DATE: 12/21/2010
APPROVED BY: D.J.C.

NOTES:

1. MATERIAL SEE TABLE

UNLESS OTHERWISE SPECIFIED:	NAME #	DATE
DRAWN	PEC	06/10/05
ORG. AUDTOR	JJ	
ORG. REC	6874	05/02/00
Q.A.		

<small>Manufactured in the U.S.A.</small>	
THE BILCO COMPANY <small>New Haven, Connecticut 06505</small>	
TITLE: BRACKET ARM GUIDE 14 1/4" & 18 7/8" W/ DETENT	
SIZE	DWG. NO.
A	SD548
SC ALE 1:2	WEIGHT
	SHEET 3 OF 3

THIS DRAWING IS THE PROPERTY OF THE BILCO COMPANY AND IS NOT TO BE REPRODUCED OR COPIED IN ANY MANNER WITHOUT THE WRITTEN CONSENT OF THE BILCO COMPANY. THE INFORMATION CONTAINED HEREIN REMAINS THE PROPERTY OF THE BILCO COMPANY. ALL RIGHTS RESERVED.

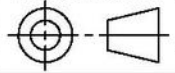

REV
F

ITEM NO.	PARTNO.	DESCRIPTION	SD38L-P	SD38LS6
1	SD38	HO A-SW, 14 1/4" ARM ASSY, STEEL	1	-
	SD38S6	HO A-SW, 14 1/4" ARM ASSY, 316SS	-	1
2	SD5A	HANDLE-HOLD OPEN ARM BENT, STEEL	1	-
	SD5AS6	HANDLE-HOLD OPEN ARM BENT, 316SS	-	1

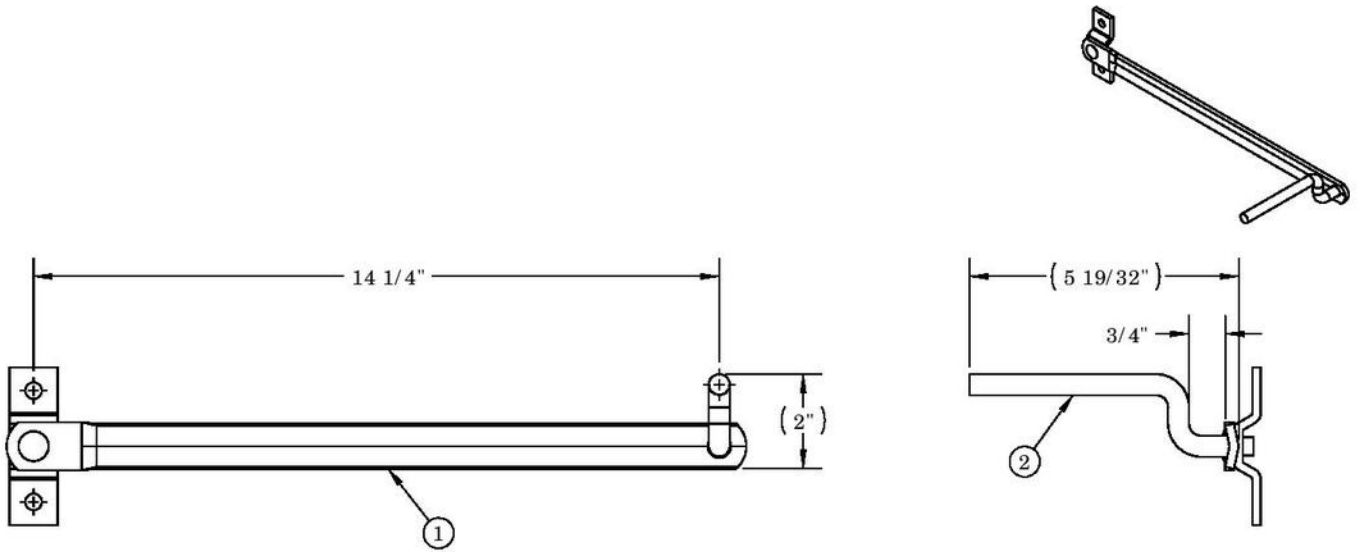

PARTNO.	DESCRIPTION
SD38L-P	HO A-SW, 14 1/4" LH ARM ASSY, PLATED
SD38LS6	HO A-SW, 14 1/4" LH ARM ASSY, 316SS

**RELEASED TO
MANUFACTURING**

DATE: 01/08/13

APPROVED BY: D.J.C.

NO TESTS.
FINISH FOR PLATED PARTS ONLY
ZINC PLATED YELLOW CHROMATE, PER ASTM B633 TYPE II SERVICE CONDITION 2

UNLESS OTHERWISE SPECIFIED:	DRAWN	NAME #	DATE
REMOVE ALL BURS & SHARP CORNERS	ATR		12/27/12
TOLERANCES:	ORG. AUDITR	HOFFMAN	
XXX ±.010	ORG. ECR		11/08/89
XX ±.015	Q.A.		
XX ±.010			
ANGLES ±.5°			
RADIUSES ±.010			

Bilco THE BILCO COMPANY
New Haven, Connecticut 06505

TITLE:
HO A-SW, 14 1/4" LH ARM ASSY

THIS DRAWING IS THE PROPERTY OF THE BILCO COMPANY AND IS TO BE KEPT IN CONFIDENTIALITY. IT IS TO BE RETURNED TO THE BILCO COMPANY UPON REQUEST. THE BILCO COMPANY ASSUMES NO LIABILITY FOR DAMAGES OF ANY KIND, INCLUDING CONSEQUENTIAL DAMAGES, ARISING FROM THE USE OF THIS DRAWING.	IN RESPECT TO METRIC TO LEGAL CONVERSION PER	MATERIAL	FINISH	DO NOT SCALE DRAWING
			SEE NOTES	



SIZE	DWG. NO.	REV
A	SD38L	D

SCALE: 1:3 WEIGHT: SHEET 1 OF 1

REV.	DESCRIPTION	ECR	BY	DATE
D	ADDED DESCRIPTION BLOCK	31383	ATR	12/27/12
C	RECREATED IN SOLIDWORKS	19171	PRC	04/12/05